

## DC or AC Valve Solenoid in Explosion-protected Design ATEX+IECEX

# 3

Product group

## G BR E 022



### Function

- Pneumatic function on valve part 3/2 NC provided by the customer
- Armature space pressure tight up to max. 50 bar static pressure
- Nominal working pressure 5 bar
- Armature with spring-supported sealing nipples at both ends



Fig. 1: Type G BR E 022 L01

### Construction

- Metal housing
- Exciter coil encapsulated
- Mounting via central thread
- Sealing between tube and valve via o-ring
- Simple exchange of the solenoid body without opening the pneumatic circuit
- Insulation materials of the excitation winding correspond to thermal class F
- Electrical connection via heat-resistant connection cable H 05 GG-F 3 G 0,75 mm<sup>2</sup>
- Protection class according to DIN VDE 0470/DIN EN 60529 when properly installed: IP 65
- Explosion protection:
  -  II 2G Ex mb IIC T5 Gb (T6 on request)
  -  II 2D Ex mb IIIC T95°C Db (T80°C on request)

### Application examples

- Actuation of 2/2- and 3/2-way-seat-valves, especially for pneumatic application and other gasiform and fluid neutral media

### Options and accessories

- Tubes with further pneumatic functions as 3/2 NO, 2/2 NC
- Fastening via flange
- Other temperature classes
- Modifications and special designs
- Please contact us for application related solutions

### Standards and approvals

- Design and testing according to DIN VDE 0580
- Quality management to ISO 9001
- ATEX, IECEX

## Technical Data

| G BR E 022 L01                      |                 | B01        | B11 |
|-------------------------------------|-----------------|------------|-----|
| Operating mode                      |                 | S1 (100 %) |     |
| Rated power $P_{20}$                | DC (W)          | 4,4        | -   |
|                                     | AC (VA)         | -          | 5,0 |
| Stroke s                            | (mm)            | 0,5        |     |
| Reference temperature               | (°C)            | 40         |     |
| Magnetic force $F_M$ without spring | stroke 0 mm (N) | 16         |     |
|                                     | stroke s mm (N) | 2,6        |     |
| Solenoid weight $m_M$               | (kg)            | 0,17       |     |
| Armature weight $m_A$               | (kg)            | 0,005      |     |

Rated voltage  $\equiv$  24 VDC, resp. 230 V / 50 Hz, the exciter coil can be adjusted to a rated voltage of maximum  $\equiv$  230 VDC resp. 230 V / 50 Hz on request.

Standard values for voltage and operating mode: 24 V DC, 230 V / 50 Hz, S1 (100%).

The force values indicated in the tables refer to 90 % of the rated voltage  $U_N \equiv$  24 V resp. 230 V / 50 Hz without spring and to the normal operating temperature.

For other rated voltages deviations of magnetic force may occur. Due to natural dispersion to force values may deviate by  $\pm 10\%$  from the values indicated in the tables.

The normal operating temperature is based on:

- Mounting on heat-insulating base
- Rated voltage: DC  $\equiv$  24 V, AC 230 V / 50 Hz (other voltages on request)
- Operating mode S1 (100 % ED)
- Reference temperature 40° C

The response times and the maximum operating frequency are not indicated, because they depend on the respective application case and pressure.

We recommend using compressed air corresponding to DIN ISO 8573/1, class 3. Elastomer neutral oils should be used for lubricating the compressed air, otherwise we ask you to please contact the manufacturer.

**Information and remarks concerning European directives** can be taken from the correspondent information sheet which is available under [Produktinfo.Magnet-Schultz.com](http://Produktinfo.Magnet-Schultz.com).

**Please make sure that the described devices are suitable for your application. Our offers for these devices are based on the assumption of maximal 8 in an FMEA severity table, i. e. in case of malfunction of the device model as offered, there is, amongst others, no jeopardy of life or limb. Supplementary information concerning its proper installation can be taken also from the  -Technical Explanation, the effective DIN VDE0580 as well as the relevant specifications.**

This part list is a document for technically qualified personnel.

The present publication is for informational purposes only and shall not be construed as mandatory illustration of the products unless otherwise confirmed expressively.

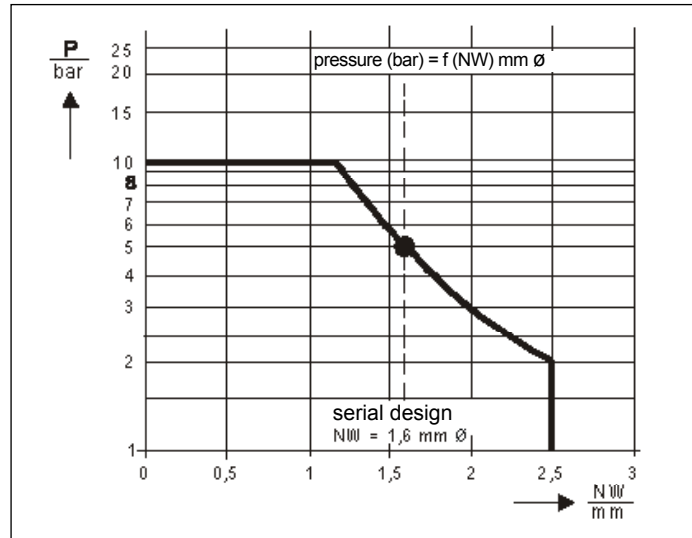
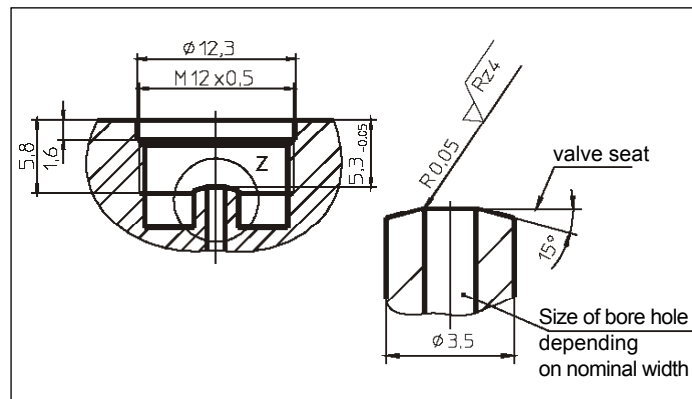

**Fig. 2** Switchable pressure as function of the nominal width of the valve seat for type G BR E 022

### Valve Construction

The valve construction shall be executed according to figure 3.

A valve seat with most possible rectangularity to the armature axis and conical profile with a smooth surface ensure a maximum performance and service life of the solenoid valve.



**Fig. 3:** Valve for type G BR E 022 L01 B01 and B11

## Constructive data

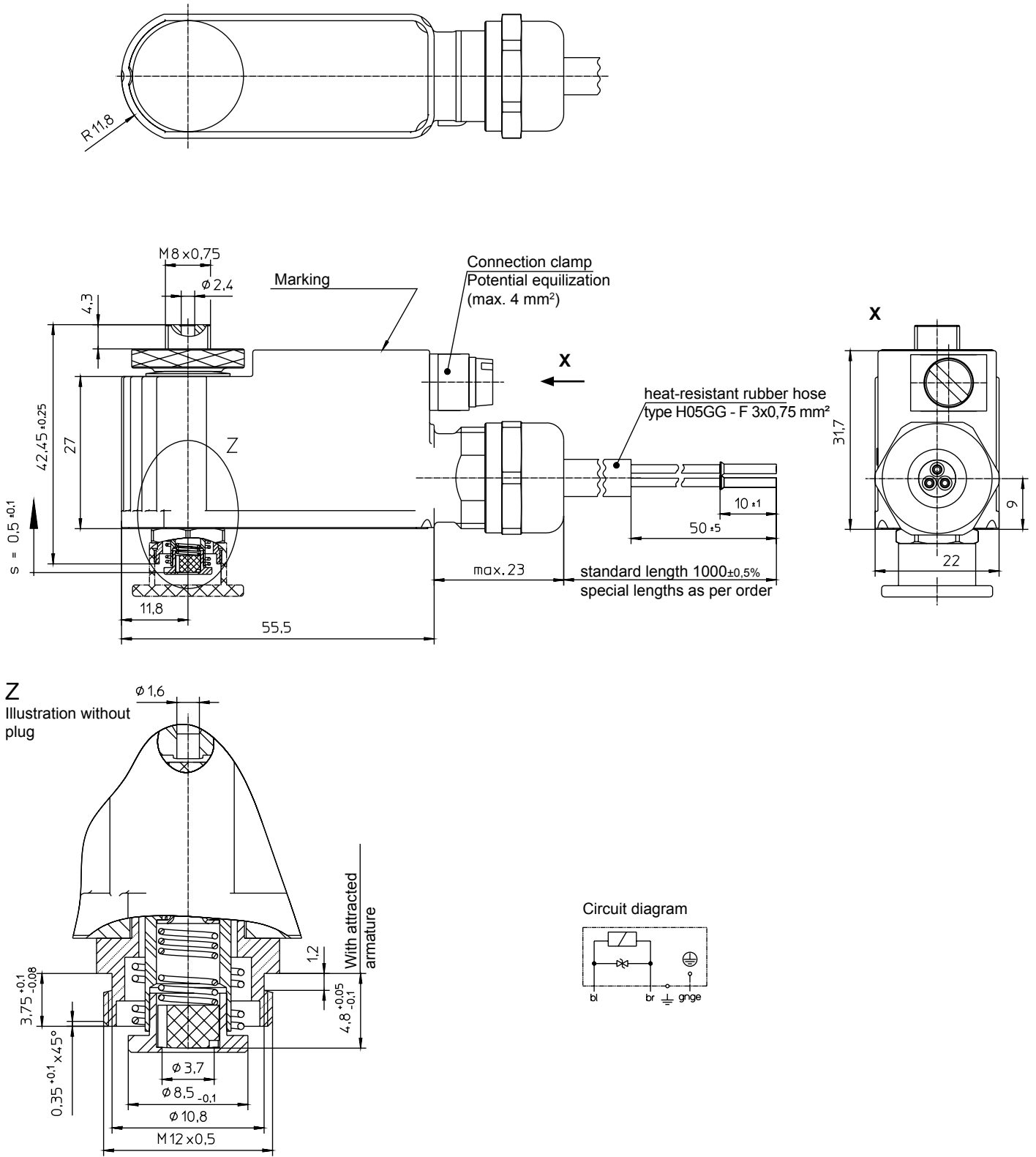

**Fig. 4:** Type G BR E 022 L01 B01 (DC)  
Type G BR E 022 L01 B11 (AC)

## Application example and switching function

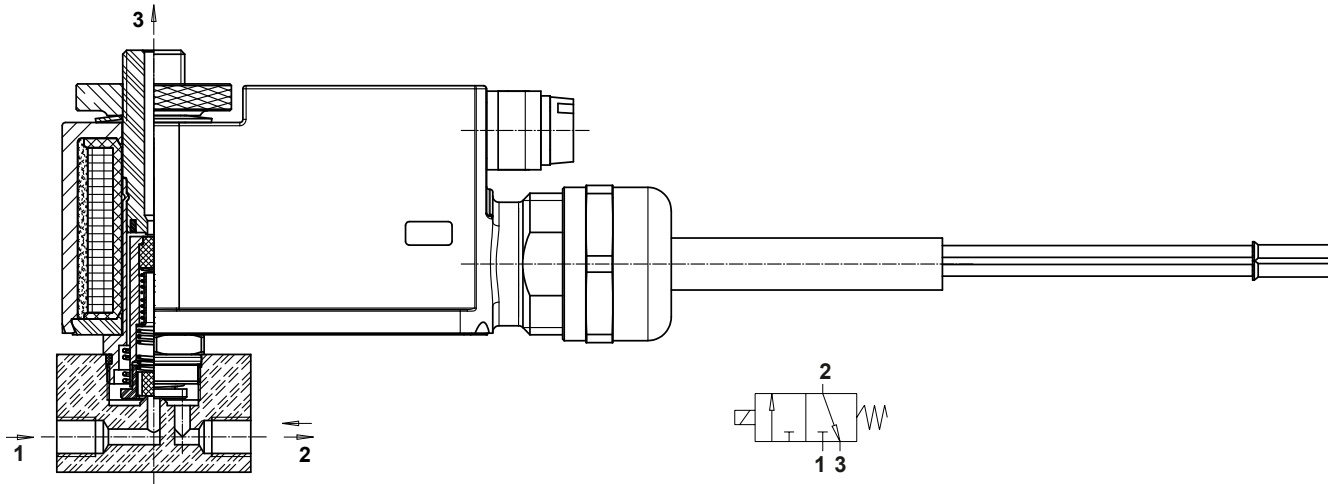

**Fig. 5** Type G BR E 022 L01 B01 (DC), Type G BR E 022 L01 B11 (AC)  
for 3/2-way valve, de-energized locked

## Order example

|    |                |                    |
|----|----------------|--------------------|
| DC | Type           | G BR E 022 L01 B01 |
|    | Voltage        | $\equiv$ 24 V DC   |
|    | Operating mode | S1 (100 %)         |
| AC | Type           | G BR E 022 L01 B11 |
|    | Voltage        | 230 V / 50 Hz      |
|    | Operating mode | S1 (100 %)         |

## Specials designs

Please do not hesitate to ask for our assistance with the solution of your application-oriented task. In order to find rapidly a reliable solution we need complete details about your application conditions. The details should be specified as precisely as possible in accordance with the relevant  -Technical Explanations.

If necessary, please request the support of our corresponding technical office.