

Proportional Solenoid for Hydraulic Application with Inductive Transducer

4

Product group

G RF ... B61, B62

Proportional solenoid

- According to DIN VDE 0580
- Armature space pressure-proof up to MSM W0120-01, test pressure static 350 bar, also suitable for dry operation
- To a large extent proportional behaviour between force and current
- Minimum hysteresis due to special precision armature bearings
- Quick response times
- Insulation materials of the excitation winding correspond to thermal class F
- Electrical connection and protection class when properly installed:
 - Plug connection by spade connectors according to DIN 46247
Protection class according to DIN VDE 0470 / DIN EN 60529 – IP 00
 - Plug connection via plug connector type Z KB according to DIN EN 175301-803
Cable gland (4 times 90° rotatable)
Protection class according to DIN VDE 0470 / DIN EN 60529 – IP 65



Fig. 1: G RF Y 035 F20 B61

Inductive transducer

- Integrated demodulation stage with carrier frequency oscillator and calibrated output sensitivity
- Two designs with limiting frequency 20 Hz and 500 Hz
- Suitable for dry and pressure-tight applications
- Pressure-tight tube, designed for 350 bar static pressure
- Mounting via square flange
- Electrical connection and protection class when properly installed:
 - Connection via surface-mounted plug Messrs. Binder M12 x 1 series 713
 - Protection to DIN VDE 0470/DIN EN 60529 – IP 65 with sealed read-out potentiometer
- EMC directive

Application examples

- In particular proportional actuator in hydraulic control chains and control loops

Technical data inductive transducer

G RF Y ... F20 ...		035, 045 ... B61	035, 045, 060 ... B62
Linear stroke	(mm)	± 4	
Supply voltage	(= V)	24 ± 10 %	
Input current	(mA)	< 50	
Sensitivity	(= V / mm)	0,5 ± 1 %	
Output voltage	(= V)	5,5 ... 9,5	
Linearity tolerance	(%)	± 1	
Top limiting frequency (-3 dB)	(Hz)	typ. 20	typ. 500
Reference temper. range	(°C)	0 ... + 50	
Temperature drift	(% / °C)	typ. 0,05	
Load resistance	(kΩ)	> 5	

Technical data for proportional solenoids see pamphlet G RF ... B01.

The rated Voltage of the proportional solenoids is = 24 V DC. If power is e. g. supplied via an electronic automatic volume control amplifier, the rated voltage has to be adjusted accordingly.
Standard values for voltage and operating mode: 24 V, S1 (100%).

Sensitivity

Sensitivity is the change in the output signal (ΔU) with reference to the change in the measuring path (Δs indicated in V/mm).

$$\text{Sensitivity} = \frac{\Delta U}{\Delta s}$$

Linearity error

The linearity error indicates the deviation of the output signal from the ideal graph in per cent.

$$\text{deviationLin} = \frac{(U_{\text{actual}} - U_{\text{nominal}})}{U_{\text{voltage stroke}}} \times 100 \%$$

Temperature drift

Temperature drift indicates in per cent the deviation of the output signal per degree of temperature change (shown in % / °C).

$$\text{deviation temp.} = \frac{(U_{\text{temp}} - U_{20^\circ\text{C}})}{U_{\text{voltage stroke}} \times \Delta T} \times 100 \%$$

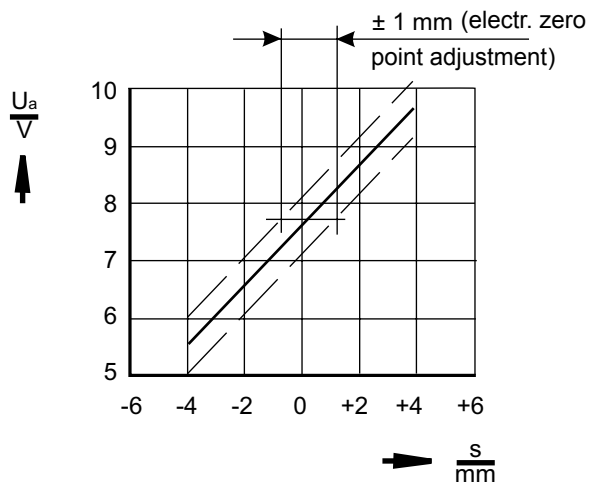

Fig. 2: Voltage vs stroke diagram for transducer with integrated electronic

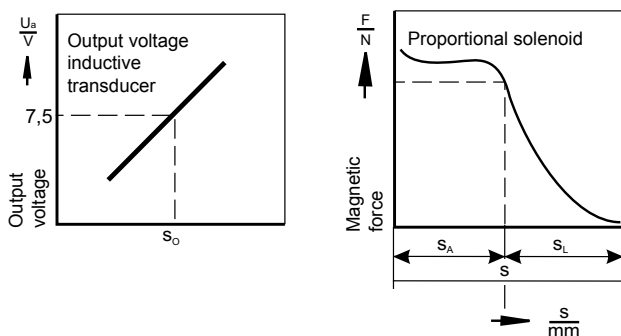

Fig. 3: Output voltage U_A depending on S, S_A, S_O

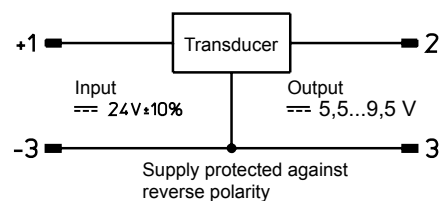

Fig. 4: Block diagram
Built-in electronics protected against wrong configuration at 1 + 3

Dimensions sheet

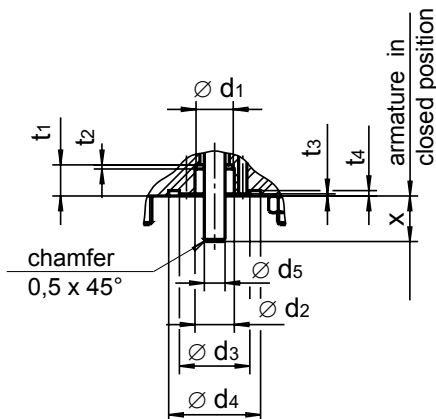
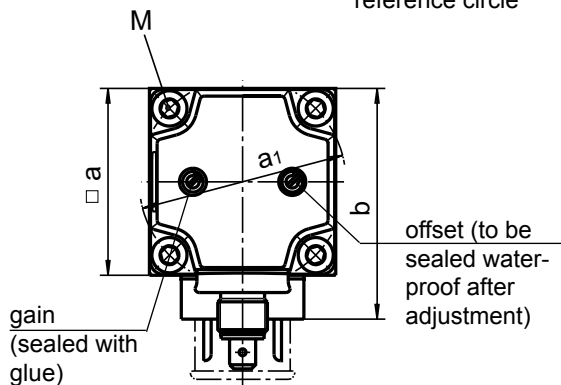
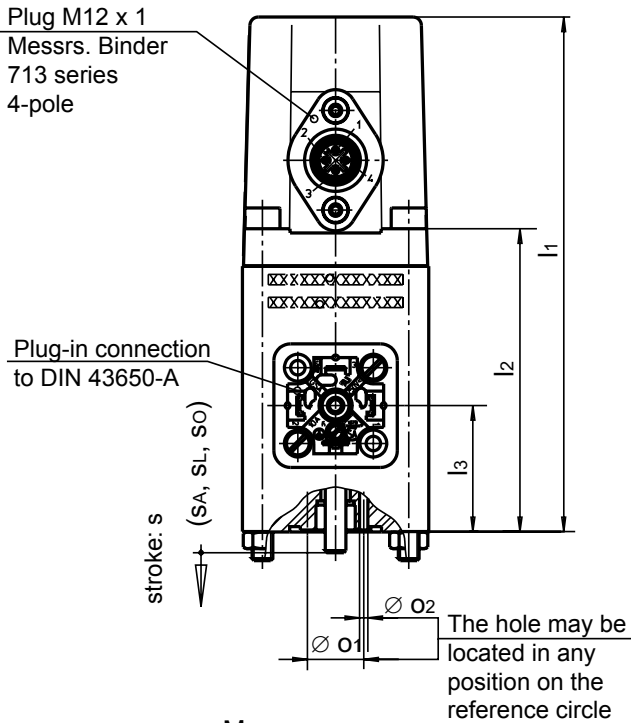
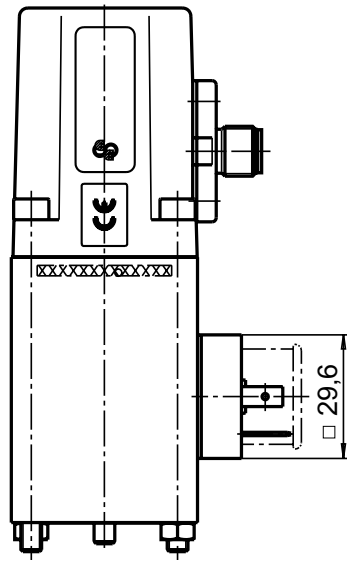



Fig. 5: Types G RF Y 035 F20 B61, B62
G RF Y 045 F20 B61, B62
G RF Y 060 F20 B62



G RF Y ... F20 B61			
G RF Y ... F20 B62			
Dimensions in mm	035	045	060
□ a	35	45	60
□ a1	28	35,35	48,1
b	45	55	70
l1	117	124	142
l2	66	73	91
l3	28,75	30,25	41,2
M	M4	M5	M6
Ø o1	1,8	2	3
Ø o2	1,2	13,6	189
t1	6,5	7,5	10
t2	1	1	2
t3	0,5 ^{+0,2}	0,5 ^{+0,2}	0,5 ^{+0,2}
t4	1,3 ^{+0,1}	1,3 ^{+0,1}	1,3 ^{+0,1}
x	7,5 ^{±0,15}	11 ^{±0,2}	12 ^{±0,2}
Ø d1	7,5	9	12
Ø d2	8	9,5	12,5
Ø d3	17	17	23,3
Ø d4	22,2 ^{±0,2}	22,2 ^{±0,2}	29,7 ^{±0,2}
Ø d5	4	5	6
S (overall stroke)	4 ^{±0,3}	6 ^{±0,3}	8 ^{±0,4}
S _W (working stroke)	2	3	4
S _I (idle stroke)	2	3	4
S ₀ transducer O-position	2	3	4
(= 7,5 V) at stroke s _A			

Information and remarks concerning European directives can be taken from the correspondent information sheet which is available under *Produktinfo.Magnet-Schultz.com*.

This part list is a document for technically qualified personnel. The present publication is for informational purposes only and shall not be construed as mandatory illustration of the products unless otherwise confirmed expressively.

Please make sure that the described devices are suitable for your application. Our offers for these devices are based on the assumption of maximal 8 in an FMEA severity table, i. e. in case of malfunction of the device model as offered, there is, amongst others, no jeopardy of life or limb. Supplementary information concerning its proper installation can be taken also from the  -Technical Explanation, the effective DIN VDE0580 as well as the relevant specifications.

Connection geometry

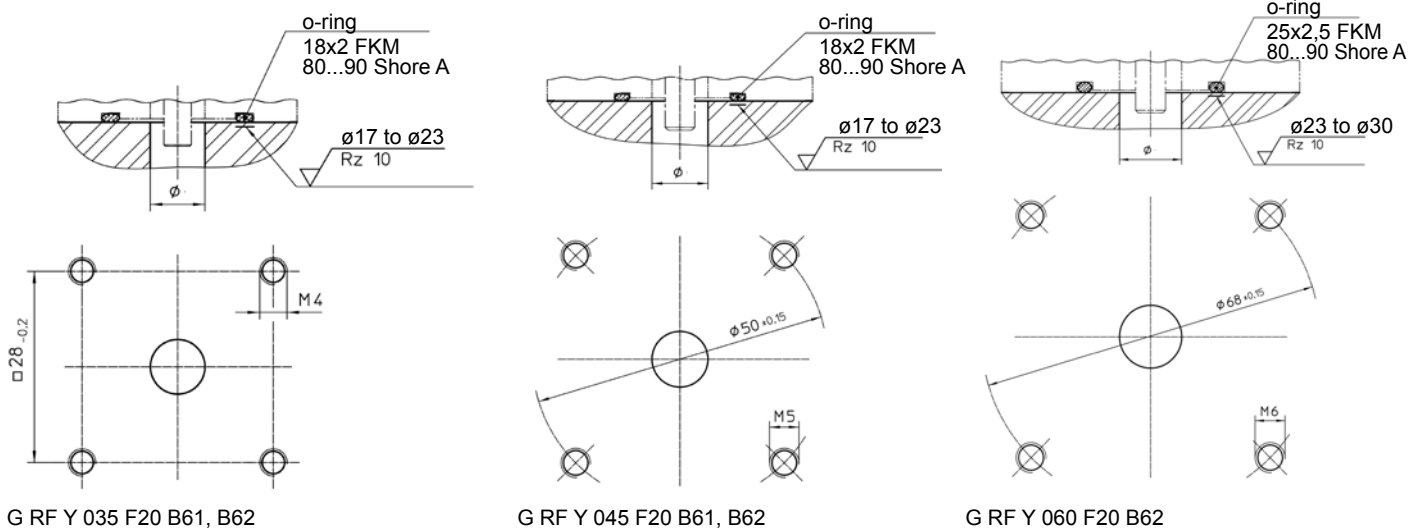

Type code

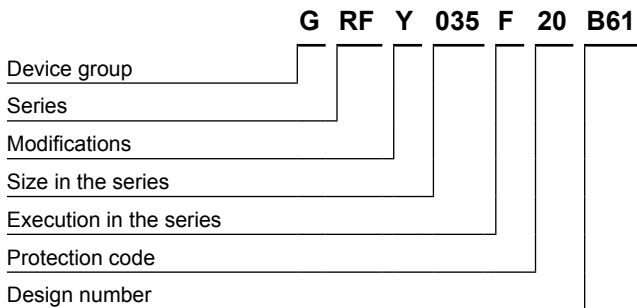

Example

Type G RF Y 035 F20 B61
Voltage == 24 V DC
Operating mode S1 (100 %)

Specials designs

Please do not hesitate to ask for our assistance with the solution of your application-oriented task. In order to find rapidly a reliable solution we need complete details about your application conditions. The details should be specified as precisely as possible in accordance with the relevant  -Technical Explanations.

If necessary, please request the support of our corresponding technical office.